

VEHICLE		E88
Model		CWE 460
Manufacturers Code		CWE64R11MJ
Model Description		6x4 Freight carrier (ADR PREP)
MASS		
Tare – total (T) *	kg	8 399
Tare Frt / Rr	kg	4366 /4033
GVM	kg	31 000
V	kg	25 700
GCM	kg	60 000
D/T kg	kg	56 000
Axle – front GA/GAU	kg	8 000
Axle – front A/AU	kg	7 700
Axle – rear GA/GAU	kg	23 000
Axle – rear A/AU	kg	18 000
*Included in tare		Standard fuel volume
PERFORMANCE		
Gradeability at V	%	87.93
Gradeability at D/T	%	40.35
Max. geared road speed	km/h	128
MAJOR DIMENSIONS		
Overall length	mm	9 447
Overall width	mm	2 480
Wheelbase	mm	5 285
CA – cab to rear axle	mm	4 445
ROH – Centre of rear axle to end of frame	mm	1 925
Turning radius (curb to curb)	mm	9 106
ENGINE		
Model		GH11E
Capacity	cm <sup>3</sup>	10 837
Layout		In line six cylinders
Type		Turbo Intercooled (Unit Injectors)
Power at r/min	kW	346 @1800
Torque at r/min	Nm	2240 @950-1400
Emissions standard		EUR V
TRANSMISSION		
Model		Escot-ATO2612F
Shift		Automated manual
No. of gears forward		12
First gear ratio		11.729
Top gear ratio		0.785
Transmission PTO		Prepared for PTO fitment

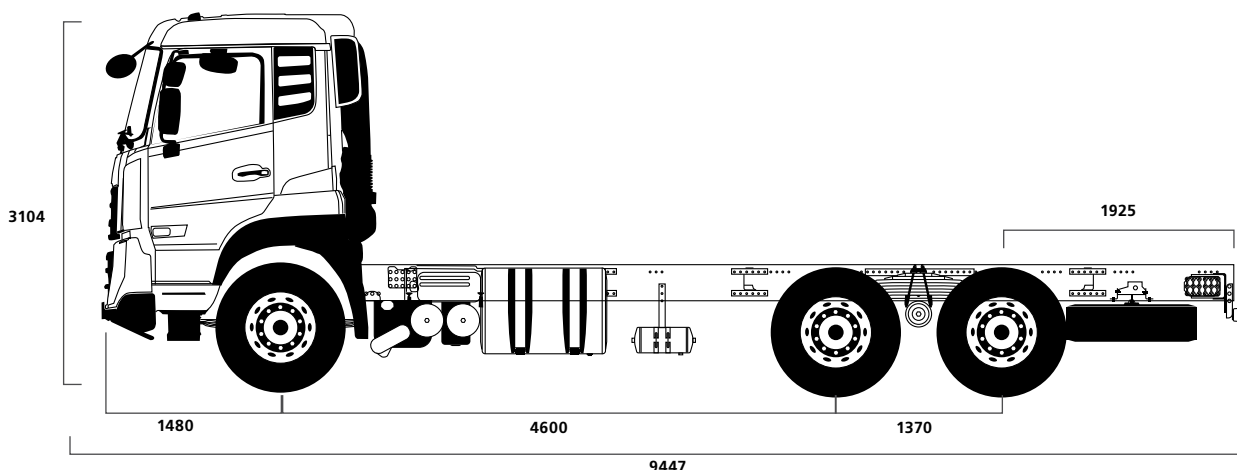

<b>CLUTCH</b>		
Model		Organic
Type		Single Plate
Diameter	mm	430mm
Operation		Automated
<b>DRIVE AXLE</b>		
Model		RTS2670B
Reduction type		Tandem Single Reduction
Final ratio		4.63
<b>SUSPENSION</b>		
Front		Parabolic leaf spring
Rear		Multileaf Spring
Shock absorbers		Standard rear
Stabilisers		Front Standard
<b>STEERING</b>		
Operation		Power Assisted
Steering Wheel Tilt & Telescopic		Standard
<b>BRAKES</b>		
System type		Full air
Front		S-cam Drum Brake
Rear		S-cam Drum Brake
Electronic brake system		ABS
Park/emergency system		Front and rear spring brakes
Exhaust brake		UD EEB (Extra compression brake with exhaust pressure governor)
Engine brake		Standard
Retarder		Standard
<b>ELECTRICAL AND FUEL</b>		
Fuel tank 1 capacity	ltrs	405 L steel tank
Fuel tank 2 capacity	ltrs	Without
AD-Blue Tank	ltrs	50
<b>TYRES</b>		
Size – front		315/80R22.5
Size – rear		315/80R22.5
<b>CAB</b>		
Type		Standard roof single sleeper (With cab back mattress)
Cab suspension		Mechanical suspension
No. of bunks		1
No. of seats		3 (Including Centre seat)
Seat Belts		Standard – ELR with Reminder (Lap Belt with Center Seat)
Seats		Fully adjustable air suspension with arm rest (Driver), Fixed passenger
Air conditioning		Standard
Radio		Standard
On-board computer		Multi Display function
Tilt cab		Electrical cab tilt
Speed limiter	km/h	80
Rear View Mirrors		6 total (Front and LHS close proximity, rear and wide angle RHS & LHS)
Electric Dashboard Outlet		12V + 24 V dash single outlet
Rear lower storage underbunk		Standard
Driver Fuel Coaching Tool		Standard
Telematics Communication Gateway		Gateway with 3G and WLAN

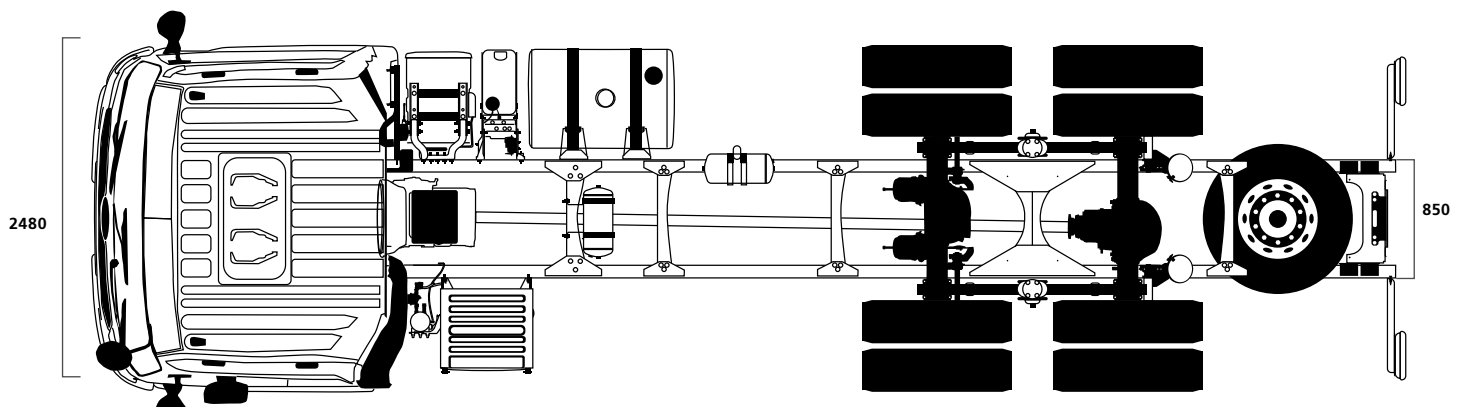

Specifications and options may differ depending on each country due to regulations or special requirements. Dimensions and devices may be changed without prior notice. Please contact your nearest UD Trucks dealer for further details.

