

VEHICLE		H50
Model		PKE 250
Manufacturers Code		PKE42RGVW18
Model Description		4x2 Tipper
MASS		
Tare – total (T) *	kg	5 184
Tare Frt / Rr	kg	3 175 / 2 009
GVM	kg	18 000
V	kg	16 000
GCM	kg	24 500
D/T kg	kg	24 500
Axle – front GA/GAU	kg	7 100
Axle – front A/AU	kg	7 100
Axle – rear GA/GAU	kg	11 000
Axle – rear A/AU	kg	9 000
*Included in tare		Standard fuel volume
PERFORMANCE		
Gradeability at V	%	43.48
Gradeability at D/T	%	28.6
Max. geared road speed	km/h	136
MAJOR DIMENSIONS		
Overall length	mm	6 509
Overall width	mm	2 486
Wheelbase	mm	3 750
CA – cab to rear axle	mm	2 946
ROH – Centre of rear axle to end of frame	mm	1 295
Turning radius (curb to curb)	mm	6 775
ENGINE		
Model		GH8E
Capacity	cm ³	7 700
Layout		In line six cylinder
Type		Turbo Intercooled (Common Rail)
Power at r/min	kW	184 @ 2 200
Torque at r/min	Nm	950 @ 1 000 – 1 800
Emissions standard		EUR V
TRANSMISSION		
Model		Allison 3000
Shift		Automatic
No. of gears forward		6
First gear ratio		3.49
Top gear ratio		0.65
Transmission PTO		488Nm, 6spd, 103% Eng Spd, ccw viewed from rear, DIN 5462-4 hole

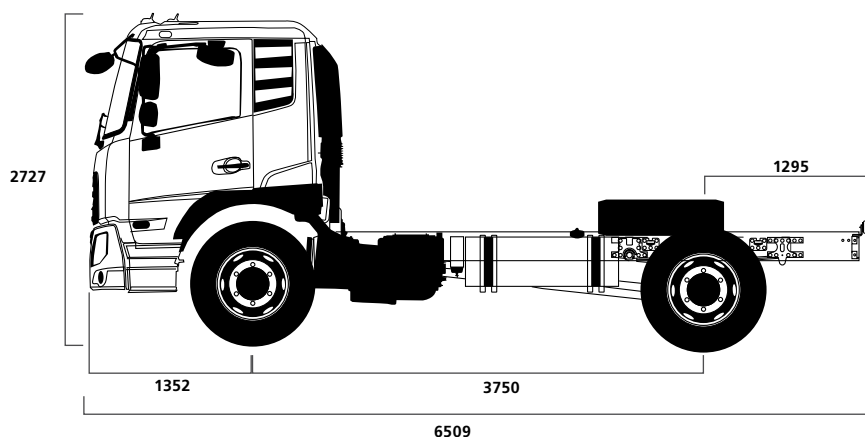

CLUTCH		
Torque converter		TC 418 (1.98:1)
DRIVE AXLE		
Model		RSS1132D
Reduction type		Single reduction single
Final ratio		5.57
SUSPENSION		
Front		Parabolic Springs (Stiff)
Rear		Multileaf Spring (Stiff)
Shock absorbers		Standard – (Double Acting Front & Rear)
Stabilisers		Front Standard
STEERING		
Operation		Power assisted
Steering Wheel Tilt & Telescopic		Standard
BRAKES		
System type		Full Air
Front		S-cam Drum Brake
Rear		S-cam Drum Brake
Electronic brake system		ABS
Park/emergency system		Spring brakes-rear
Auxiliary brakes		Engine brake with exhaust pressure governor
ELECTRICAL AND FUEL		
Fuel tank 1 capacity	ltrs	190
Fuel tank 2 capacity	ltrs	Without
AD-Blue Tank	ltrs	20
TYRES		
Size – front		295/80R22.5
Size – rear		295/80R22.5
CAB		
Type		Sleeper Cab(Without cab back mattress)
No. of bunks		1
No. of seats		3 (Includes Center Seat)
Window lift		Electrical window lift (both)
Seat Belts		Standard – ELR with Reminder (Lap Belt with Center Seat)
Seats		Fully adjustable, with Fire Retardant Material
Seat suspension		Air suspension (Driver 's seat)
Air conditioning		Standard
Radio		Standard
On-board computer		Multi Function Display & In Vehicle Diagnostics
Tilt cab		Mechanical
Speed limiter	km/h	80km/h
Day time running lights		Without
Rear View Mirrors		6 total (Front and LHS close proximity, rear and wide angle RHS & LHS)
Electric Dashboard Outlet		12V + 24V dash single outlet
Overhead Storage Console		Standard
Driver Fuel Coaching Tool		Standard in Multi Function Display
Telematics Communication Gateway		Gateway with 3G and WLAN

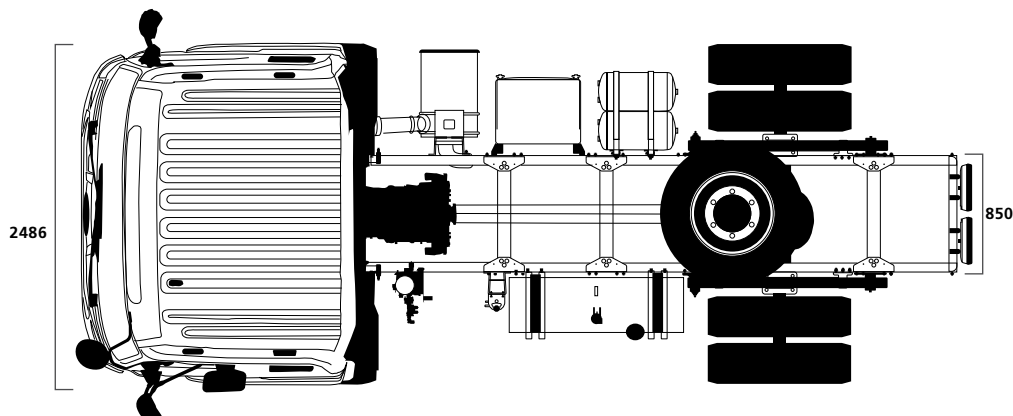

Specifications and options may differ depending on each country due to regulations or special requirements. Dimensions and devices may be changed without prior notice. Please contact your nearest UD Trucks dealer for further details.

