



UD TRUCKS

Quester

CWE370

E51

VEHICLE		E51
Model		CWE 370
Manufacturers Code		CWE64R11MJ
Model Description		6x4 Freight Carrier
MASS		
Tare – total (T) *	kg	8 298
Tare Frt / Rr	kg	4 269/4 029
GVM	kg	31 000
V	kg	25 700
GCM	kg	45 000
D/T	kg	45 000
Axle – front GA/GAU	kg	8 000
Axle – front A/AU	kg	7 700
Axle – rear GA/GAU	kg	23 000
Axle – rear A/AU	kg	18 000
* Tools included in tare		Yes
PERFORMANCE		
Gradeability at V	%	67.1
Gradeability at D/T	%	38.3
Max. geared road speed	km/h	114.4
MAJOR DIMENSIONS		
Overall length	mm	9 975
Overall width	mm	2 500
Wheelbase	mm	5 885
CA – cab to rear axle	mm	5 095
ROH – Centre of rear axle to end of frame	mm	2 610
Turning radius (curb to curb)	mm	10 000
ENGINE		
Model		GH11E
Capacity	cm ³	10 837
Layout		In line six cylinders
Type		Turbo Intercooled (Unit Injectors)
Power at r/min	kW	278 @ 1 900
Torque at r/min	Nm	1 734 @ 1 000-1 400
Emissions standard		EUR III
TRANSMISSION		
Model		Escot-ATO2612F
Shift		Automated manual
No. of gears forward		12
First gear ratio		11.729
Top gear ratio		0.785
Transmission PTO		Prepared for PTO fitment

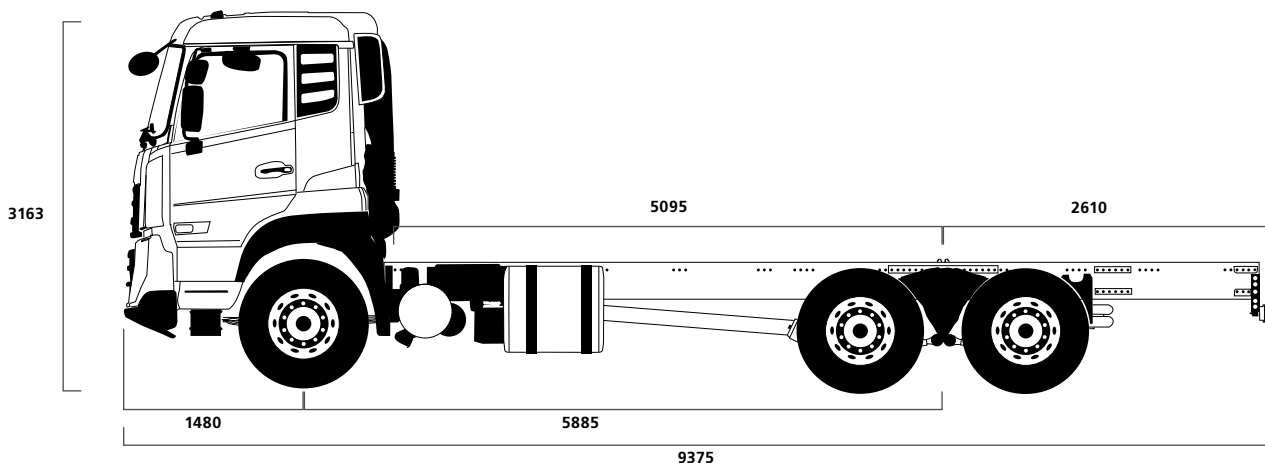

CLUTCH		
Model		Organic
Type		Single Plate
Diameter	mm	430
Operation		Automated
DRIVE AXLE		
Model		RTS2670B
Reduction type		Tandem Single Reduction
Final ratio		4.63
SUSPENSION		
Front		Parabolic leaf spring
Rear		Multileaf Spring
Shock absorbers		Standard front
Stabilisers		Front Standard
STEERING		
Operation		Power Assisted
Steering Wheel Tilt & Telescopic		Standard
BRAKES		
System type		Full air
Front		S-cam Drum Brake
Rear		S-cam Drum Brake
Electronic brake system		ABS
Park/emergency system		Front and rear spring brakes
Exhaust brake		Standard
Engine brake		Standard
Retarder		Without retarder
ELECTRICAL AND FUEL		
Fuel tank 1 capacity	ltrs	405 Steel tank
Fuel tank 2 capacity	ltrs	Without
TYRES		
Size – front		315/80R22.5
Size – rear		315/80R22.5
CAB		
Type		Standard roof single sleeper (No cab back mattress)
Cab suspension		Mechanical suspension
No. of bunks		1
No. of seats		3 (Including Centre seat)
Seat Belts		Standard – ELR with Reminder (Lap Belt with Center Seat)
Seats		Fully adjustable air suspension with arm rest (Driver), Fixed passenger
Air conditioning		Standard
Radio/USB		Standard
On-board computer		Multi Display function
Tilt cab		Mechanical
Speed limiter	km/h	80
Rear View Mirrors		6 total (Front and LHS close proximity, rear and wide angle RHS & LHS)
12 Volt Power Outlet		Standard in Dash
Rear lower storage underbunk		Without
Driver Fuel Coaching Tool		Standard
Telematics Communication Gateway		Gateway with GSM/GPRS/EDGE

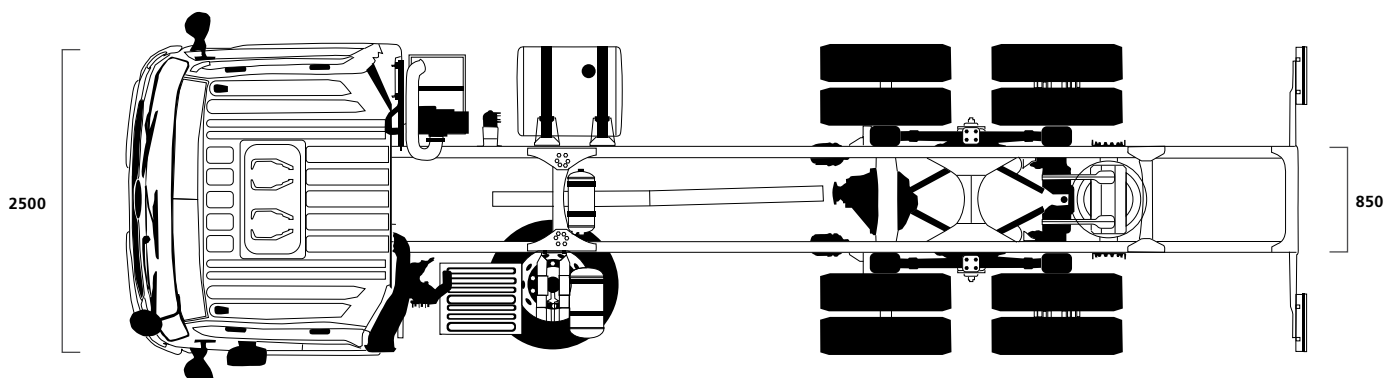

Specifications and options may differ depending on each country due to regulations or special requirements. Dimensions and devices may be changed without prior notice. Please contact your nearest UD Trucks dealer for further details.

