



UD TRUCKS

Quester

CGE370

E47

VEHICLE		E47
Model		CGE370
Manufacturers Code		CGE84R11MJ
Model Description		8x4 Mixer Chassis
MASS		
Tare – total (T) *	kg	9 430
Tare Frt / Rr	kg	5 970 / 3 460
GVM	kg	38 000
V	kg	33 000
GCM	kg	45 000
D/T kg	kg	45 000
Axle – front GA/GAU	kg	15 000
Axle – front A/AU	kg	15 000
Axle – rear GA/GAU	kg	23 000
Axle – rear A/AU	kg	18 000
* Included in tare		Tools and Spare Wheel (Excluding Fuel)
PERFORMANCE		
Gradeability at V	%	56.5
Gradeability at D/T	%	38.3
Max. geared road speed	km/h	102
MAJOR DIMENSIONS		
Overall length	mm	9 675
Overall width	mm	2 500
Wheelbase	mm	5 287
CA – cab to bogie/rear axle	mm	3 295
ROH-Centre of bogie/rear axle to end of frame	mm	1 910
Turning radius (curb to curb)	mm	9 100
ENGINE		
Model		GH11E
Capacity	cm ³	10 837
Layout		In line six cylinder
Type		Turbo Intercooled (Unit Injectors)
Power at r/min	kW	278 @ 1 900
Torque at r/min	Nm	1 734 @ 1 000 – 1 400
Emissions standard		EUR III
Engine PTO		Flange SAE410-4 hole. 650Nm, ccw-rear view, ratio: 93% Eng. Spd
External engine control		Control lever & harness supplied loose in cab
TRANSMISSION		
Model		Allison 4440 (AL446)
Shift		Full Automatic
No. of gears forward		6
First gear ratio		4.7
Top gear ratio		0.67
Transmission PTO		Prepared for PTO fitment

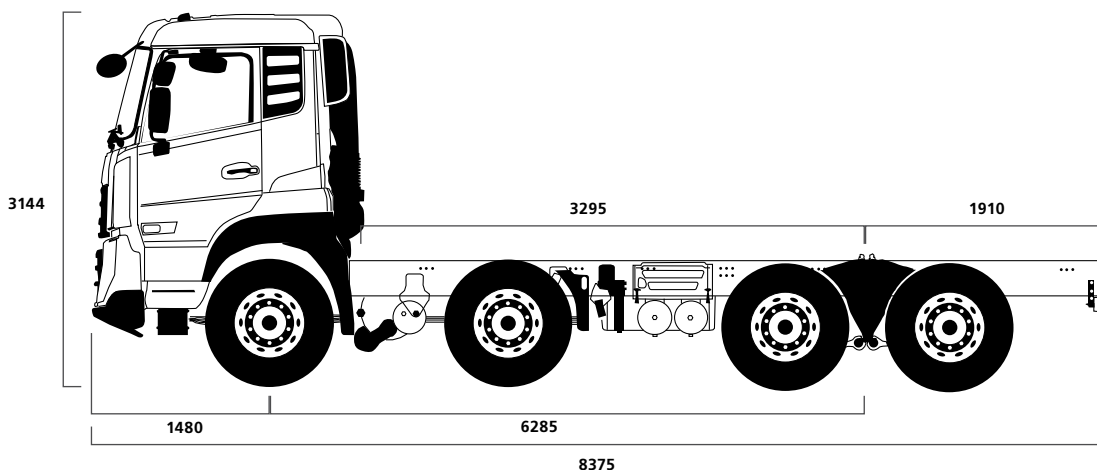

TORQUE CONVERTER		
Model		Allison TC541(Ratio 1.9)
DRIVE AXLE		
Model		RTS2670B
Reduction type		Single Reduction Tandem
Final ratio		6.17
SUSPENSION		
Front		Parabolic Springs
Rear		Multileaf Spring
Shock absorbers		Standard (Front)
Stabilisers		Standard (Front)
STEERING		
Operation		Power Assisted
BRAKES		
System type		Full Air
Front		S-cam Drum Brake
Rear		S-cam Drum Brake
Electronic brake system		ABS
Park/emergency system		Spring brakes-front and rear
Exhaust brake		Standard
Engine brake		Standard
Retarder		Standard
ELECTRICAL & FUEL		
Fuel tank 1 capacity	ltrs	210 L RH Side Mounted
Fuel tank 2 capacity	ltrs	None
TYRES		
Size – front		315/80R22.5
Size – rear		315/80R22.5
CAB		
Type		Standard roof single sleeper (Without cab back mattress)
Cab suspension		Mechanical Suspension
No. of bunks		1
No. of seats		2
Seat Belts		Standard – ELR with Reminder
Seats		Fully adjustable air suspension with arm rest (Driver), Fixed passenger
Air conditioning		Standard
Radio/USB		Standard
On-board computer		Multi Display function
Tilt cab		Mechanical
Speed limiter	km/h	80
Rear View Mirrors		6 total (Front and LHS close proximity, rear and wide angle RHS & LHS)
12 Volt Power Outlet		Standard in Dash
Rear lower storage underbunk		Without
Driver Fuel Coaching Tool		Standard
Telematics Communication Gateway		Gateway with GSM/GPRS/EDGE

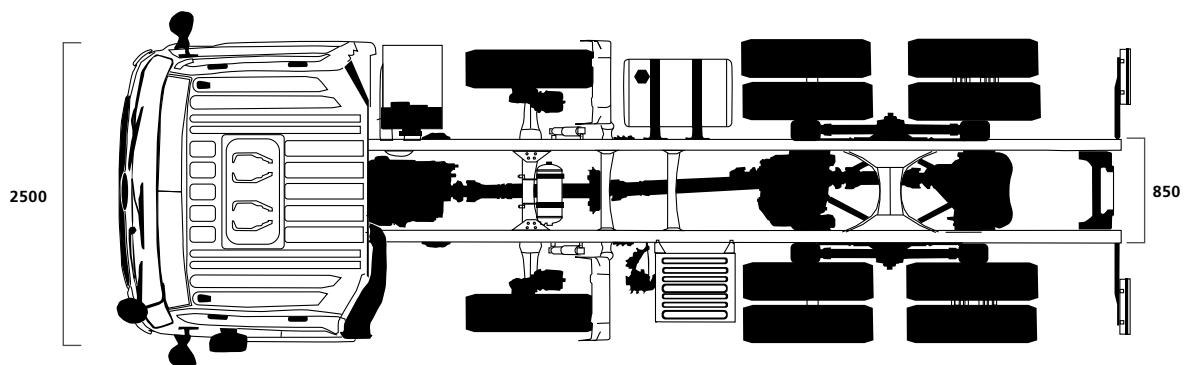

Specifications and options may differ depending on each country due to regulations or special requirements. Dimensions and devices may be changed without prior notice. Please contact your nearest UD Trucks dealer for further details.

